

THE VANDERVEEN PROJECT STANDARD FORM

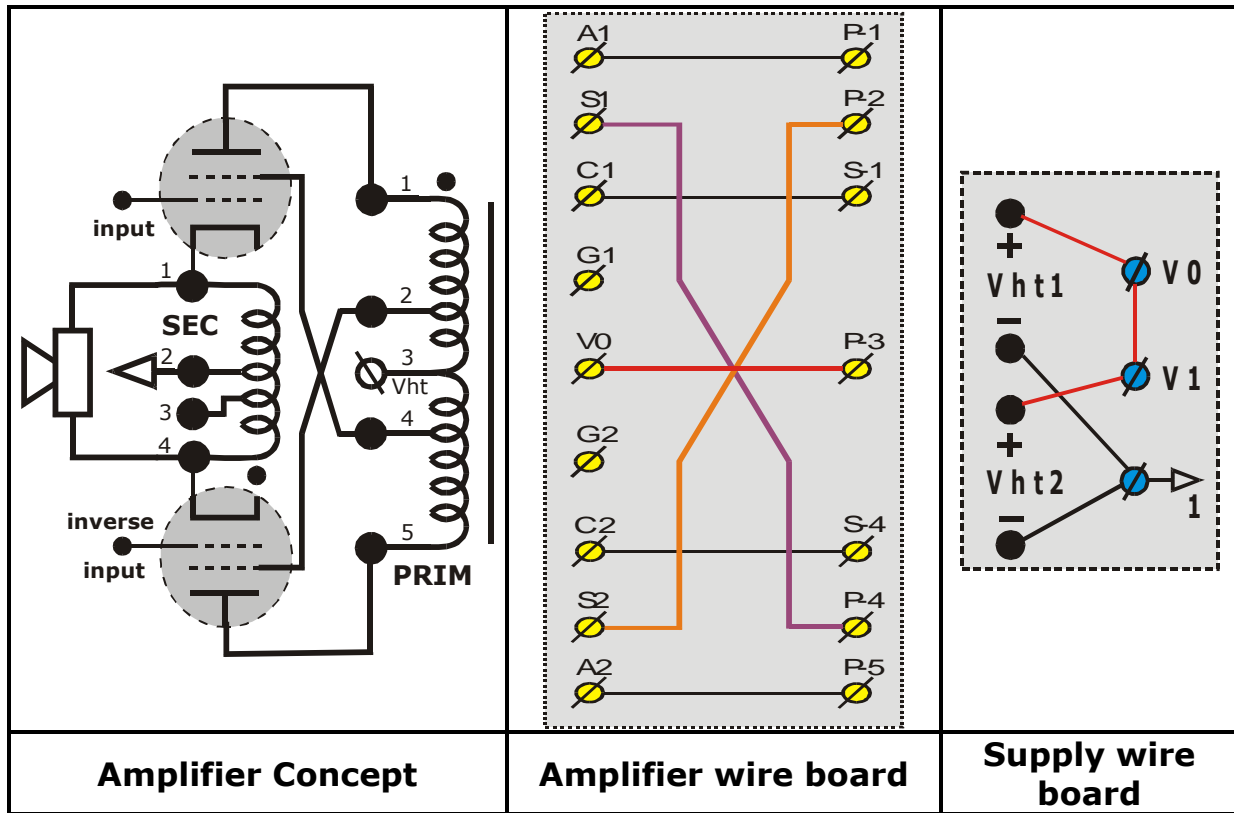

Number, Name	circuit-13 : pp-Super-Pentode	Units
I_0 per tube	50	[mA]
Connect 4Ω to	sec. taps 1 and 3	[-]
P-max @ 1 kHz	26	[Watt]
f-lowest @ P-max	13	[Hz]
-3dB freq-range	8 Hz – 56 kHz	[Hz-kHz]
A(unloaded)	46.6	[-]
A (4Ω loaded)	11.1	[-]
Z-out	12.8	[Ω]
DF (8Ω reference)	0.63	[-]

Remarks:

- 1) Powerful but harsh, not optimal pleasant for the ears
- 2) Suited for guitar amplification, especially in overdrive
- 3) Soft overdrive
- 4) Low damping, colored vacuum tube amp sound character
- 5) Shows details in the sound stage, but not all
- 6) Reacts on the impedance variation versus frequency of the speaker
- 7) See the description for explanation of the harsh character