

THE VANDERVEEN PROJECT STANDARD FORM

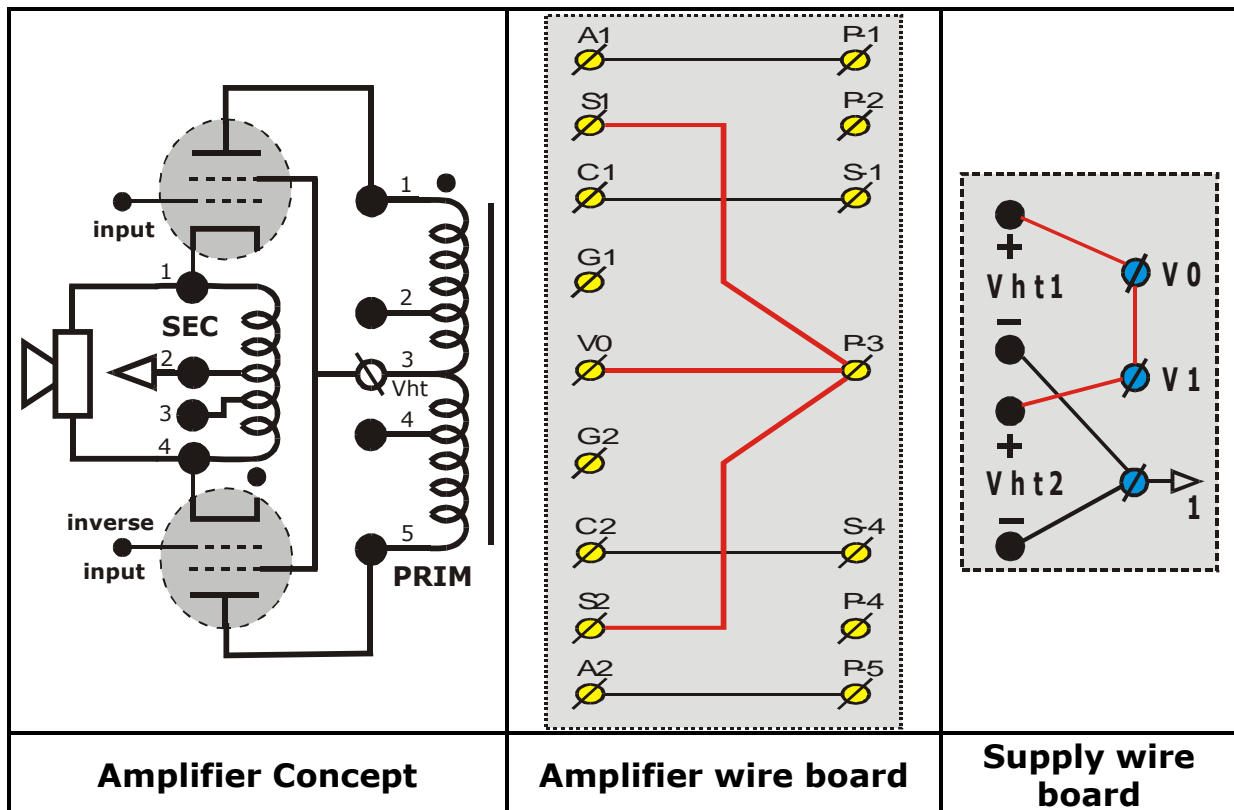

Number, Name	circuit-14 : PP Pentode + CFB	Units
I_0 per tube	50	[mA]
Connect 4Ω to	sec. taps 1 and 3	[-]
P-max @ 1 kHz	30	[Watt]
f-lowest @ P-max	14	[Hz]
-3dB freq-range	8 Hz - 51 kHz	[Hz-kHz]
A(unloaded)	20	[-]
A (4Ω loaded)	8	[-]
Z-out	6	[Ω]
DF (8Ω reference)	1.3	[-]

Remarks:

- 1) Powerful and dynamic
- 2) Very suited for clean and open sounding guitar amplification
- 3) Soft overdrive
- 4) Medium damping, little colored valve amp sound character
- 5) Shows details in the sound stage, but not all