

THE VANDERVEEN PROJECT STANDARD FORM

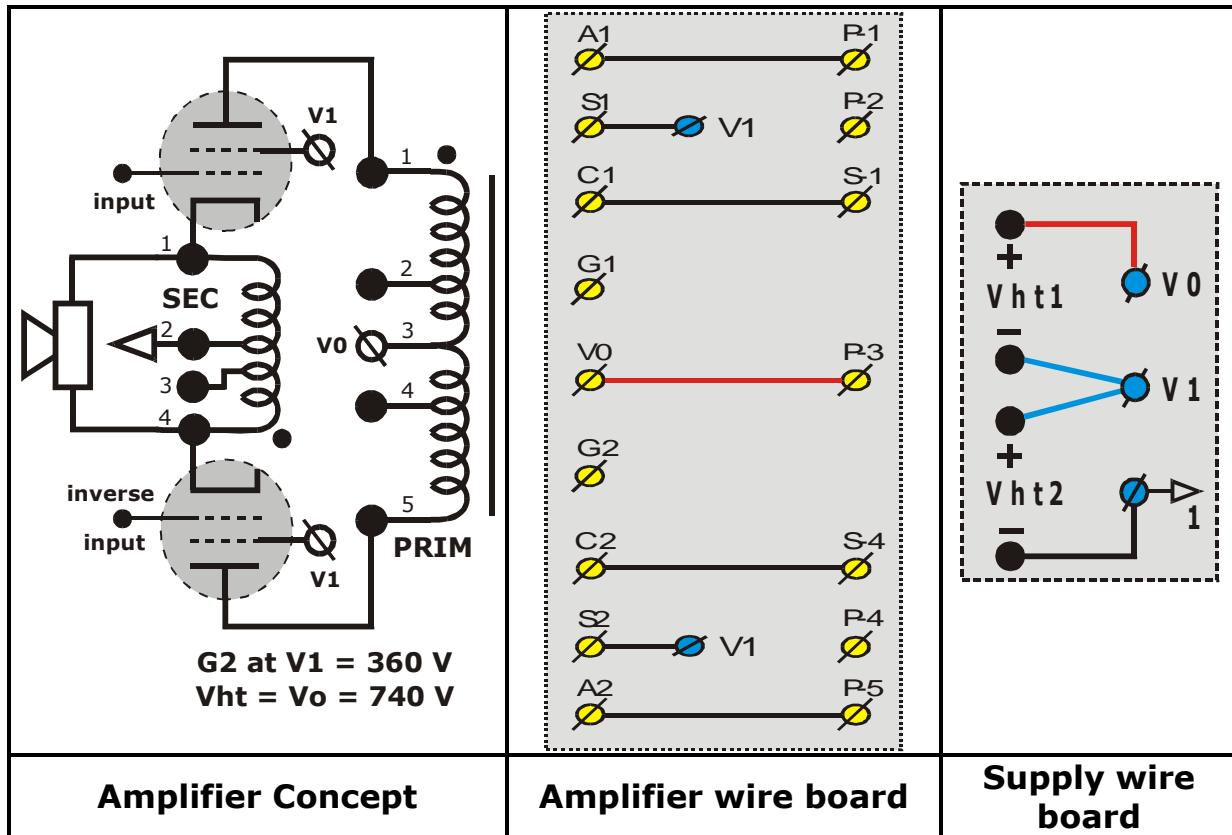

Number, Name	20 : PP Pentode @ 740 V + CFB	Units
I ₀ per tube	25 (EL34); 50 (EL156)	[mA]
Connect 4 Ω to	sec. taps 1 and 2; Z _{aa} = 8000 Ω	[-]
P-max @ 1 kHz	72-continuu, 91-peak	[Watt]
f-lowest @ P-max	24	[Hz]
-3dB freq-range	8 Hz – 38 kHz	[Hz-kHz]
A(unloaded)	14.6	[-]
A (4 Ω loaded)	7.1	[-]
Z-out	4.2	[Ω]
DF (8 Ω reference)	1.9	[-]

Remarks:

- 1) Very powerful and dynamic amplifier
- 2) Good damping factor, for more apply some overall negative feedback
- 3) Bass sounds controlled, very suitable for guitar
- 4) Delivers a dynamic loud and open soundstage
- 5) Measurements are with EL34 (25 mA per tube). Use 50 mA with EL156