

VANDERVEEN-TRANS-PP80 corrections. Vs. April 2025

[See *audioXpress* May-2023 pp. 21-28]

The listing below shows corrections on our audioXpress VDV-T-PP80 article.
If you find other items, please be so kind to warn us at: info@mennovanderveen.nl

- 1) **R12 is wrongly indicated ONLY on the driver-PCB.** There its value reads 47kOhm. The correct value is: **R12 = 41k2**. In all circuit diagrams and the BOM this value is mentioned correctly.
- 2) **The START-UP procedure contains a mistake in step-5.** The correct version is:
 5. Check on the driver-PCB **on opamps-1 and -2** at their opamp-outputs (pin-1 and pin-7) to read less than 5 mVdc with reference to ground.
- 3) **Figure 7 contains a number mistake where to measure the phases of the driver signals:**
Please see the correct figure below: the measuring positions are H11 en H10 (not H17)

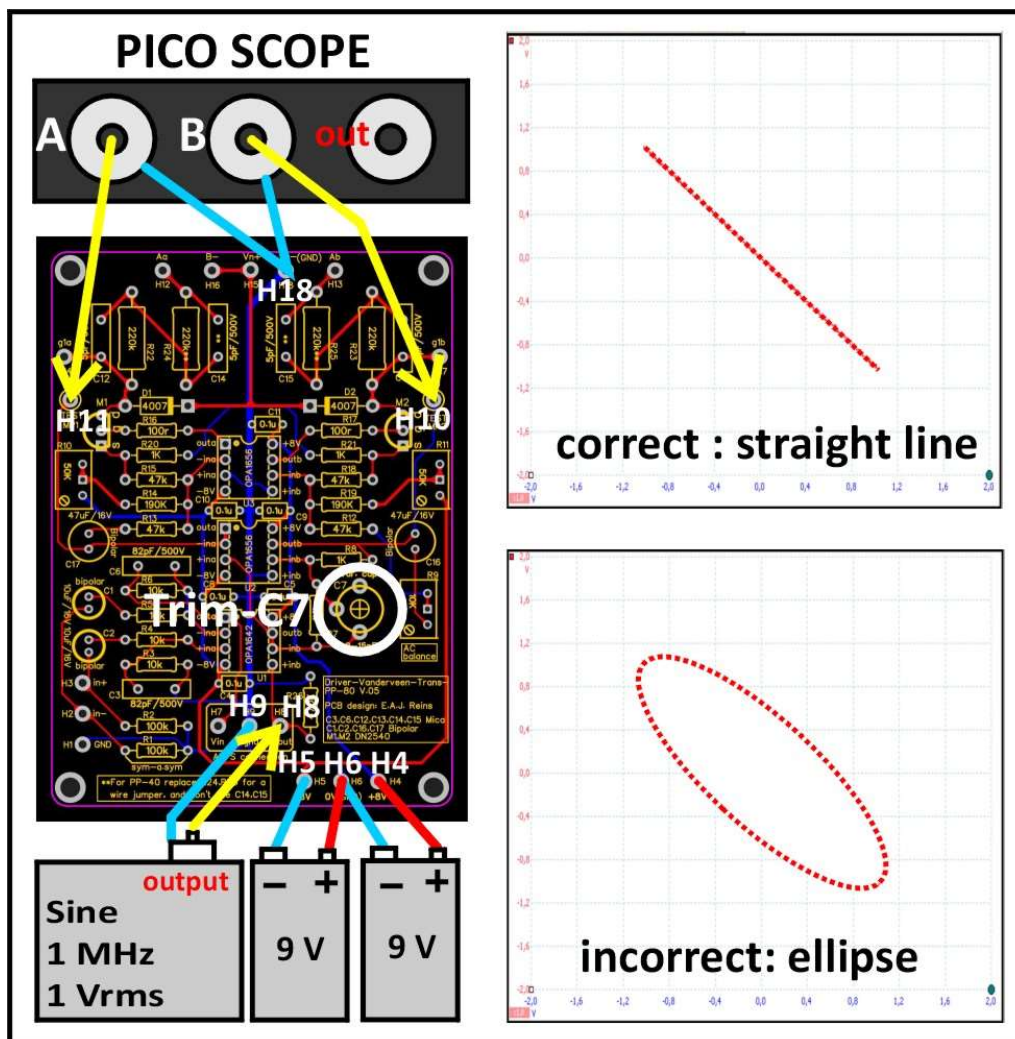

- 4) **New power supply design to compensate for temperature-drift.** Some constructors informed us that the two 360 Vdc supply sections show some drift when the amplifier gets hot. We discovered that the 170 Vz zener diodes D_{8,9} and D_{18,19} were too sensitive for temperature change. Figure-4-1 shows the original supply circuit with this zener diode stabilization.

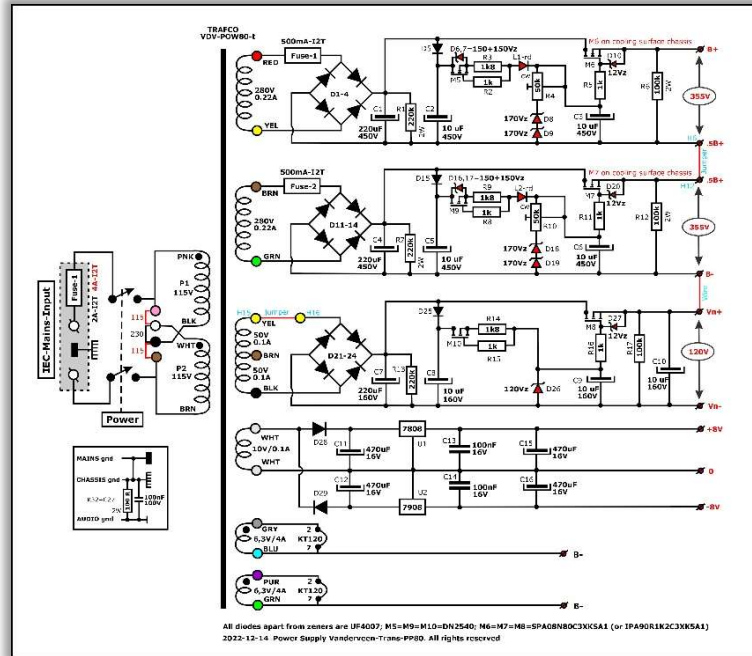

Figure-4-1: Original power supply circuit as published in audioXpress May 2023 pp 20-28.

We decided to make a new sturdy stabilized power supply. Figure-4-2 shows the “Maida circuit” with its Fet-regulators (placed on the cooling chassis and connected at jumpers J4 and J8) around voltage stabilizers LT3083 en LT3080. For the two 360 Vdc sections we also applied an extra Maida-circuit (see Fets M1,2) to guarantee voltage headroom for proper functioning of the internal LT3083 opamps.

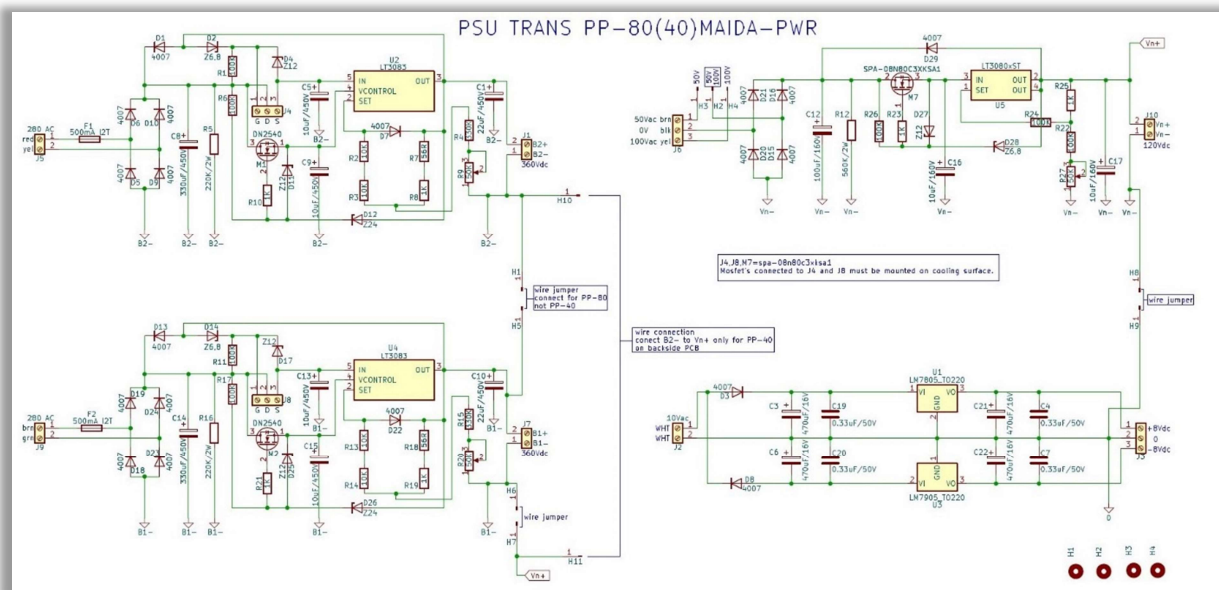

Figure-4-2: The new “double-Maida” power supply circuit for the Vanderveen-Trans-PP80

Figure-4-3 shows the new power-supply PCB with dimensions 140/105 mm (the previous version was 140/97 mm). To make exchange easy the four M3-holes are at the same positions in both PCB's.

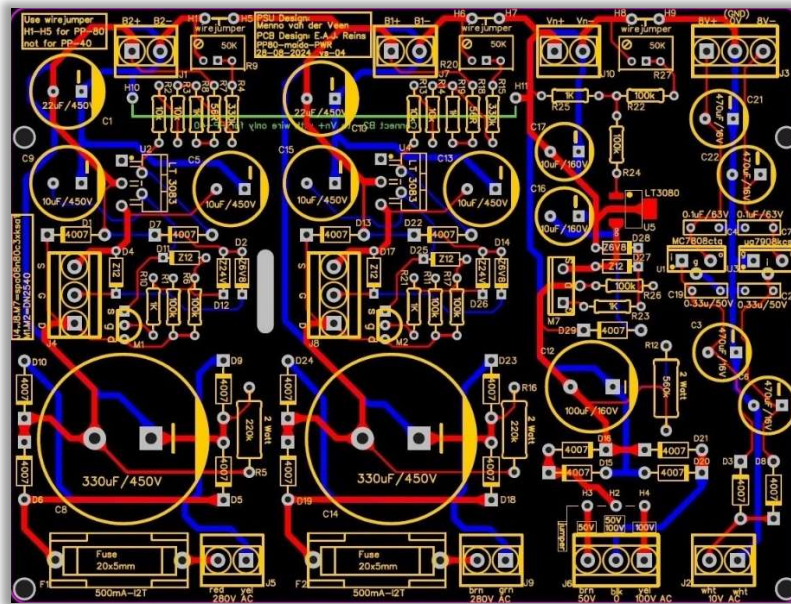

Figure-4-3 shows the new double-Maida-power-supply-PCB, designed by Erwin Reins

In the May-2023 audioXpress publication the two 360 Vdc supplies were indicated by B-, ½ B+ and B+. The new PCB uses {B1- to B1+} = 360 Vdc and {B2- to B2+} = 360 Vdc; see figures 4-2 and 4-4 for the details.

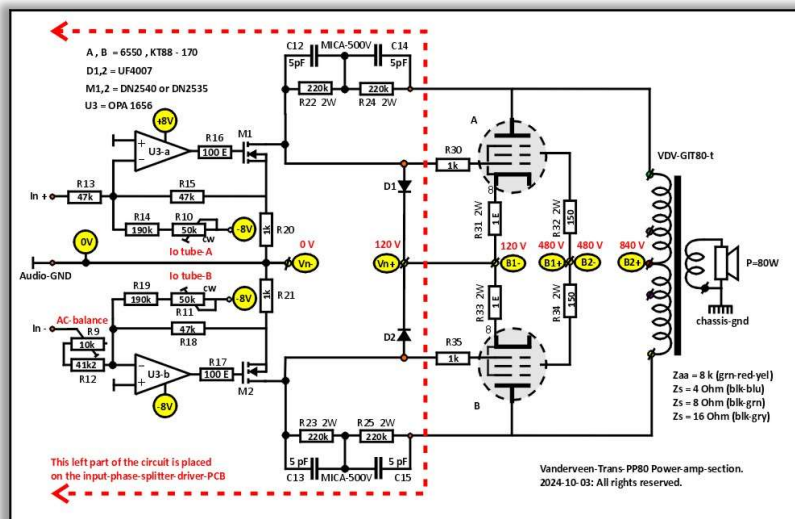

Figure-4-4 shows how to connect B1-, B1+ , B2- and B2+

Please visit www.meten-en-aan-buizenversterkers.nl for buying the new PCB and to find the BOM for ordering components.

- 5)
- 6)